

Item	Qty.	Description
1	1	38" h Oval Vertical Extrusion
2	1	38" h Oval Vertical Extrusion
3	1	38" h Oval Vertical Extrusion
4	1	38" h Oval Vertical Extrusion
5/5A	1/1	31.9499" Curved Horizontal Extrusion
6/6A	2/2	16.238" w Horizontal Extrusion
7/7A	1/1	23.8296" Curved Horizontal Extrusion
8	1	34.4170" h Vertical Extrusion

Steps:

- 1) Attach horizontal extrusions [5, 6, & 7] between vertical extrusions [1, 2, 3, & 4].
- 2) Attach vertical extrusion [8] to the center of curved horizontal extrusion [5].
- 3) Attach door to vertical extrusion [3] as shown. Refer to *Door Attachment* detail.
- 4) Drop inserts between vertical grooves as shown with arrows.
- 5) Attach horizontal extrusions [5A, 6A, & 7A] between vertical extrusions [1, 2, 3, & 4].
- 6) Velcro attach shelf supports to inside of assembled pedestal.
- 7) Place internal shelf on installed shelf supports.
- 8) Install counter top to assembled pedestal.
- 9) Attach graphic to front of pedestal using stand-off barrels and screw caps.

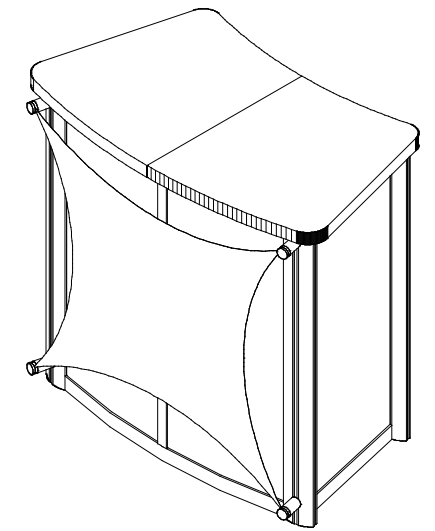

When assembled

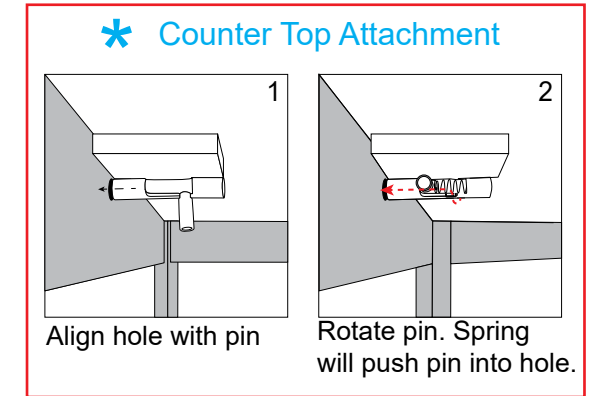
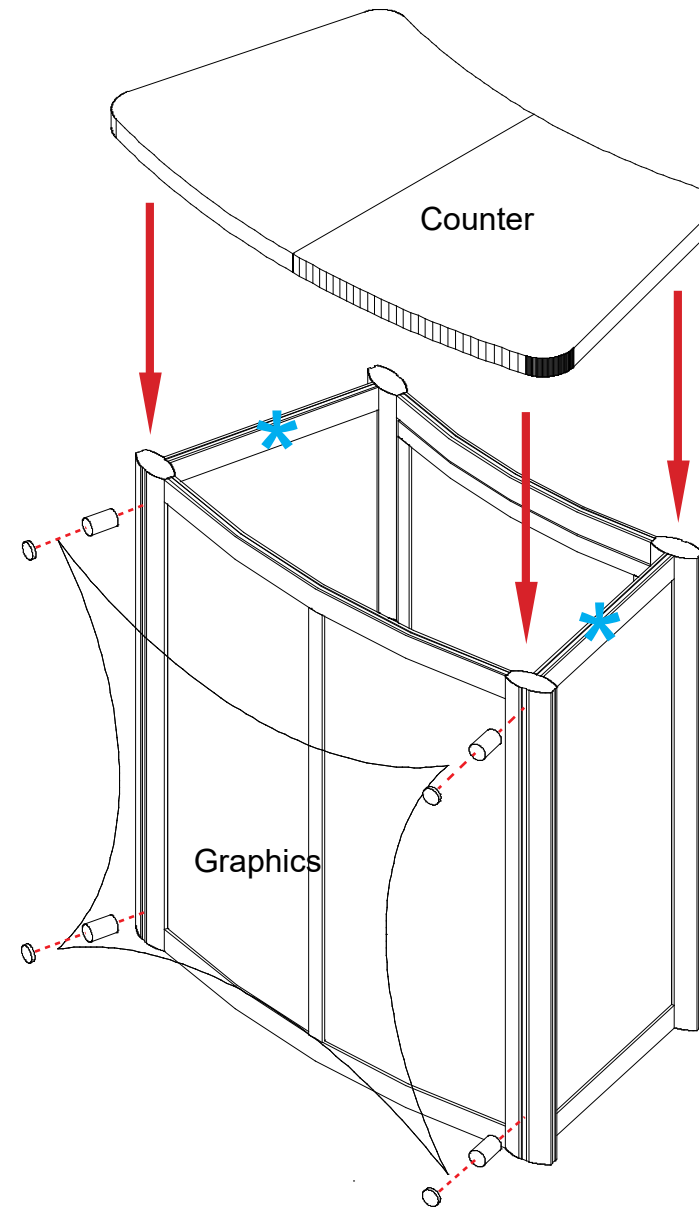
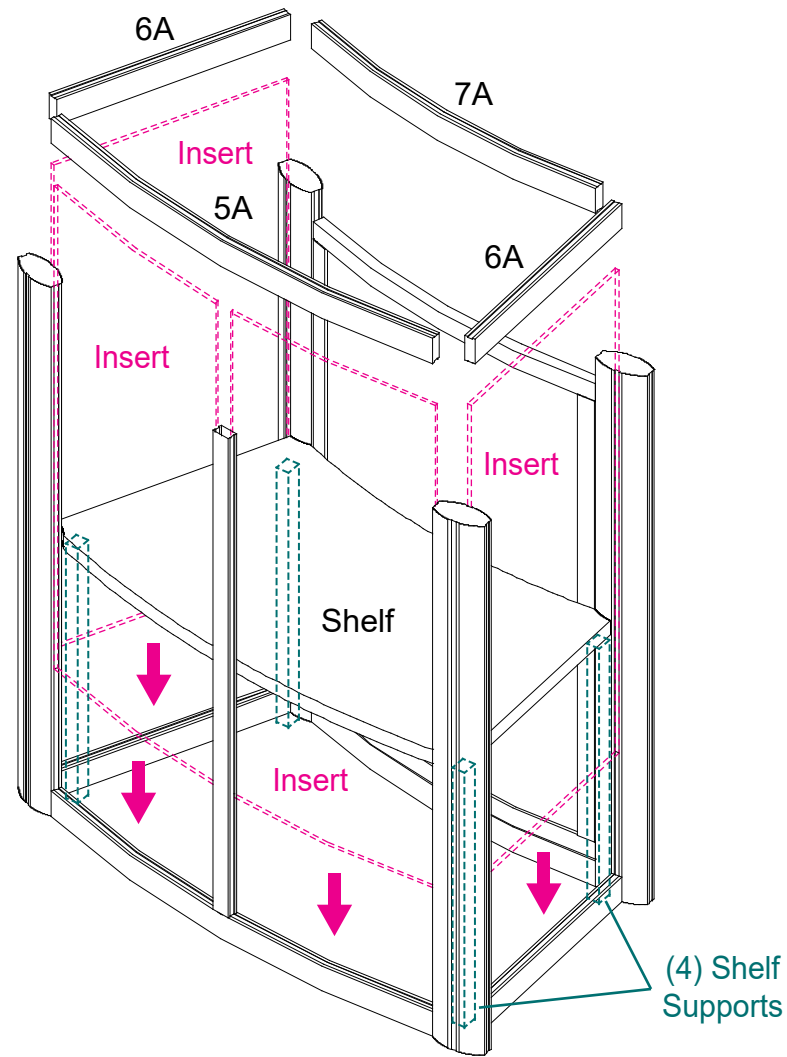
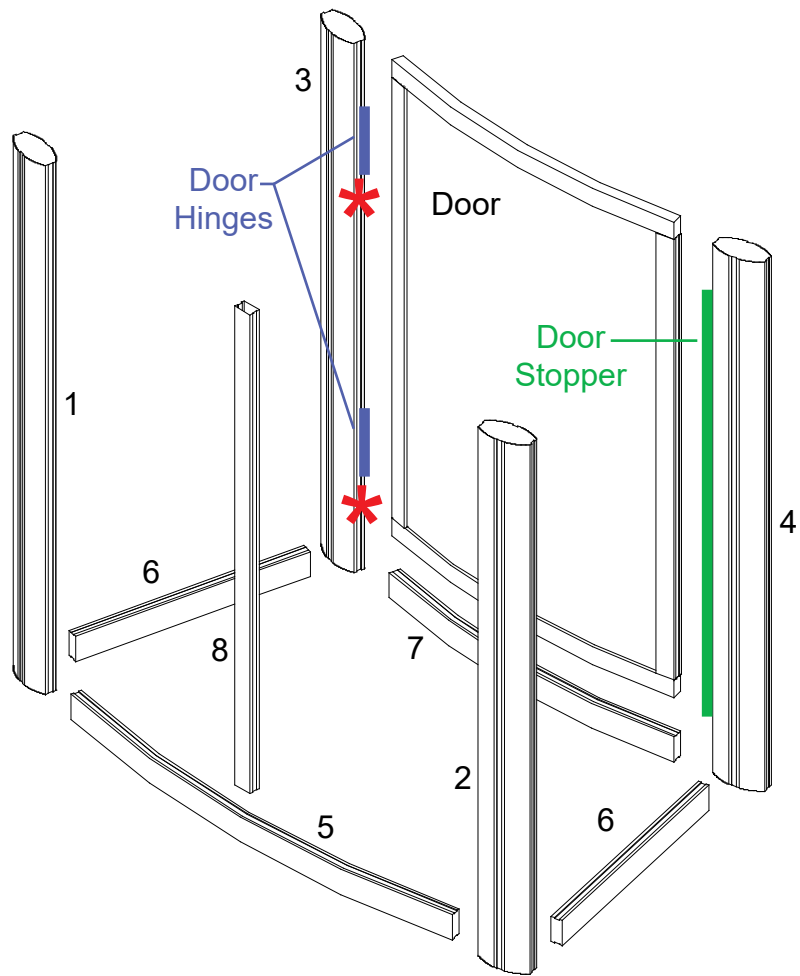

SETUP INSTRUCTIONS

General Setup Instructions

- Read entire setup instruction manual prior to unpacking parts and pieces.
- The setup instructions are created specifically for this configuration.
- Setup instructions are laid out sequentially in steps, including exploded views with detailed explanation for assembly.

Cleaning & Packing

- For Cleaning Metal, Plex, & Laminate Parts: Use a **MILD NON-ABRASIVE** cleanser and soft cloth/paper towel to clean all surfaces.
- Keep exhibit components away from heat and prolonged sun exposure.
Heat and UV exposure will warp and fade components.
- Retain all provided Packing Materials. All provided packing materials are for ease of repacking & component protection.

Disassembly

- For loss prevention, tighten all set screws and locks during disassembly.

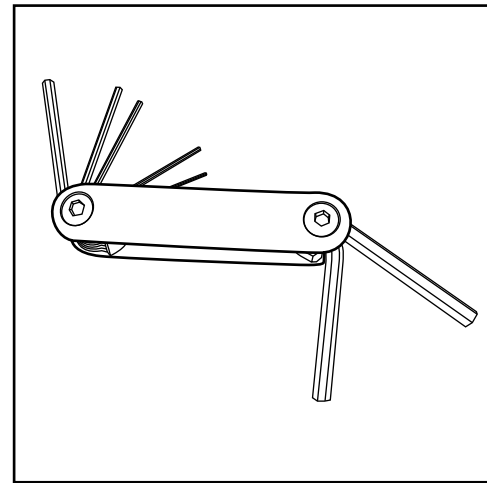

Hex Tool - Essential for Assembly

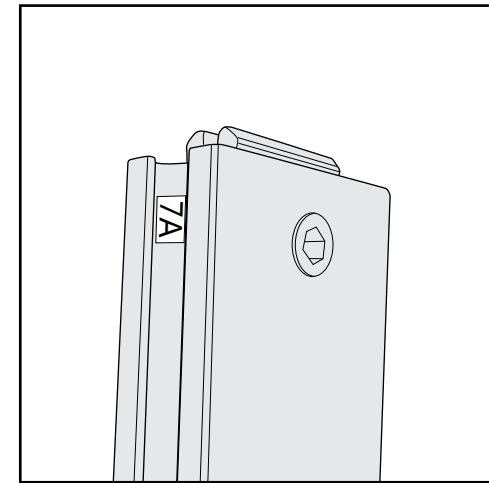

Part Identification - Numbering

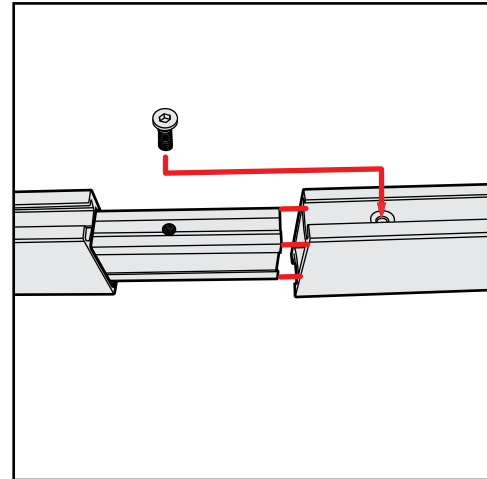

Spline Connection

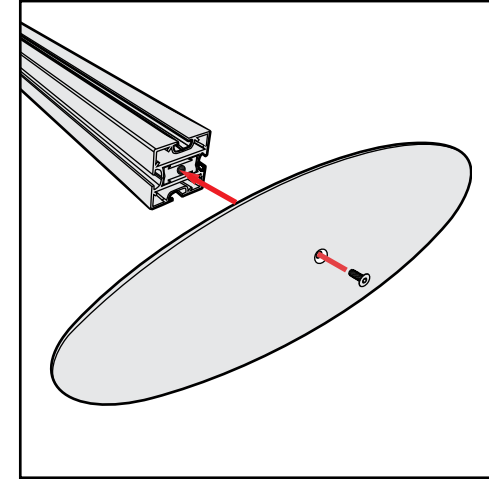

Base Plate & Extrusion Connection

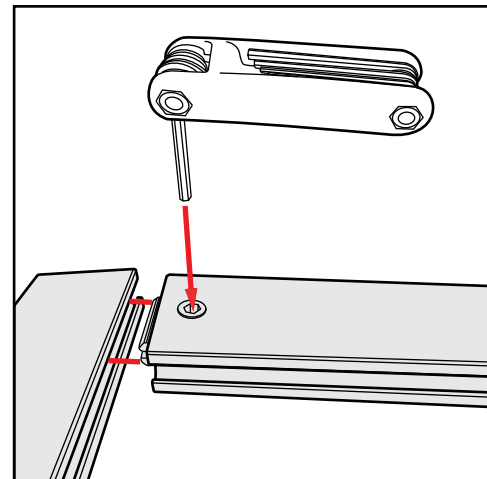

Extrusion & Lock Connection

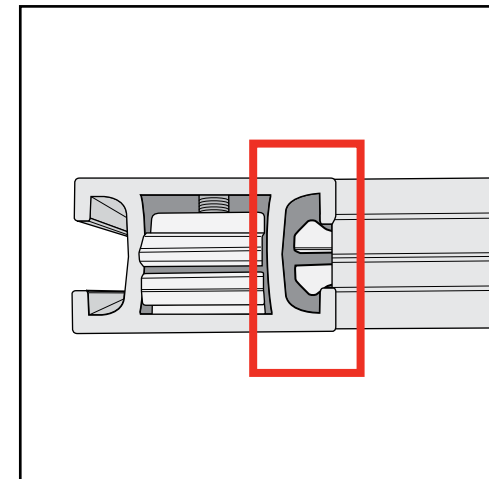

Engaged Lock



WARNING



DO NOT USE POWER TOOLS

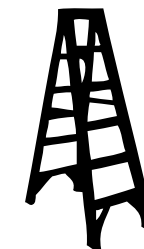

LADDERS OR LIFTS
MAY BE REQUIRED



ALL CONNECTIONS MUST
BE TIGHTLY SECURED

Top View of Each Level

Pedestal Components

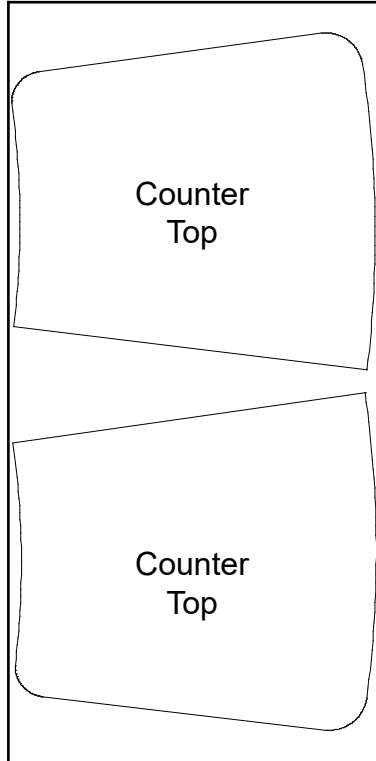

Level 1

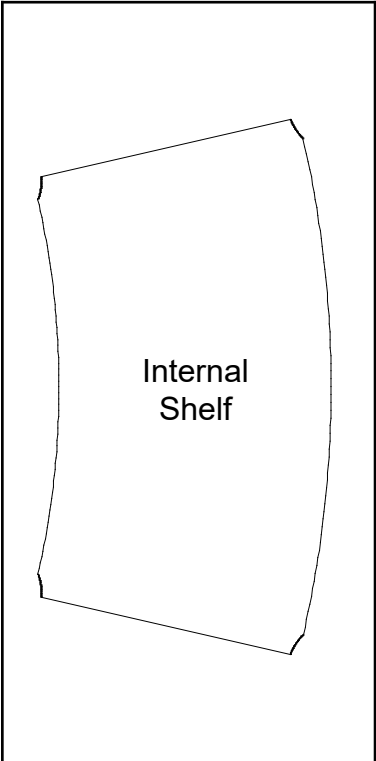

Level 2

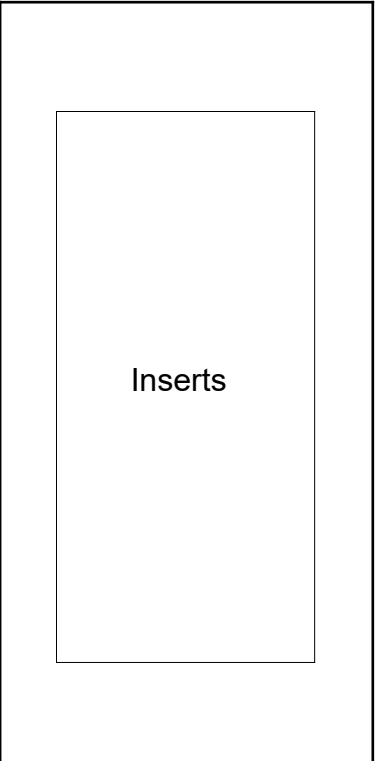

Level 3

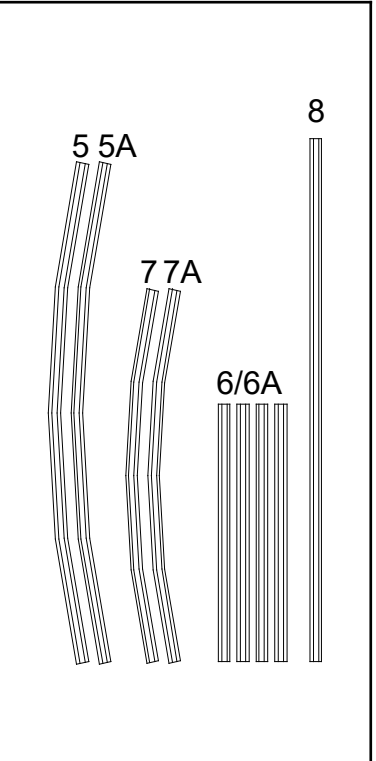

Level 4

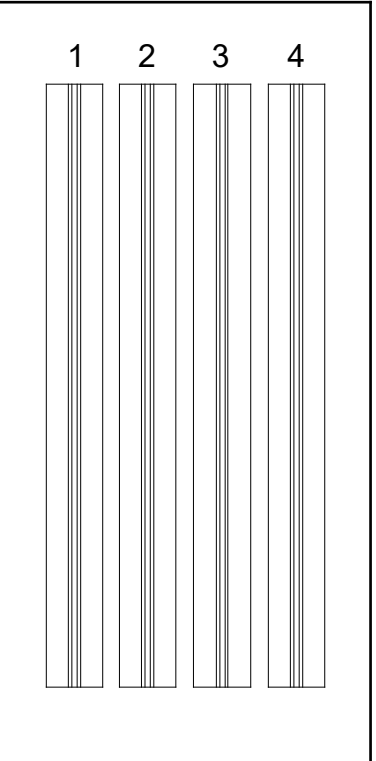

Level 5

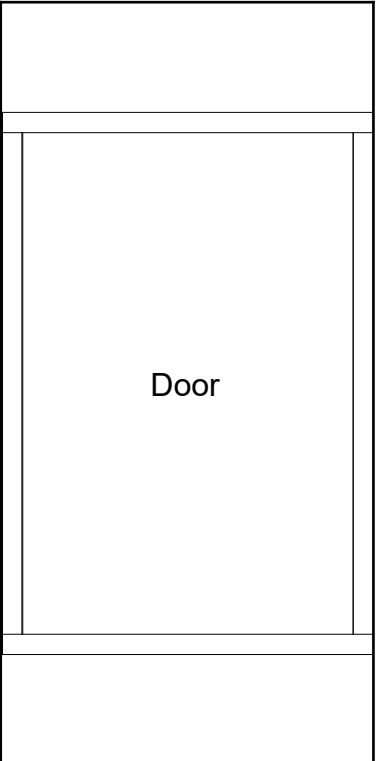

Level 6